

# INSTALLATION GUIDE

SEEN IRIS 860 Sensor

SEEN IRIS 860 Cab Box

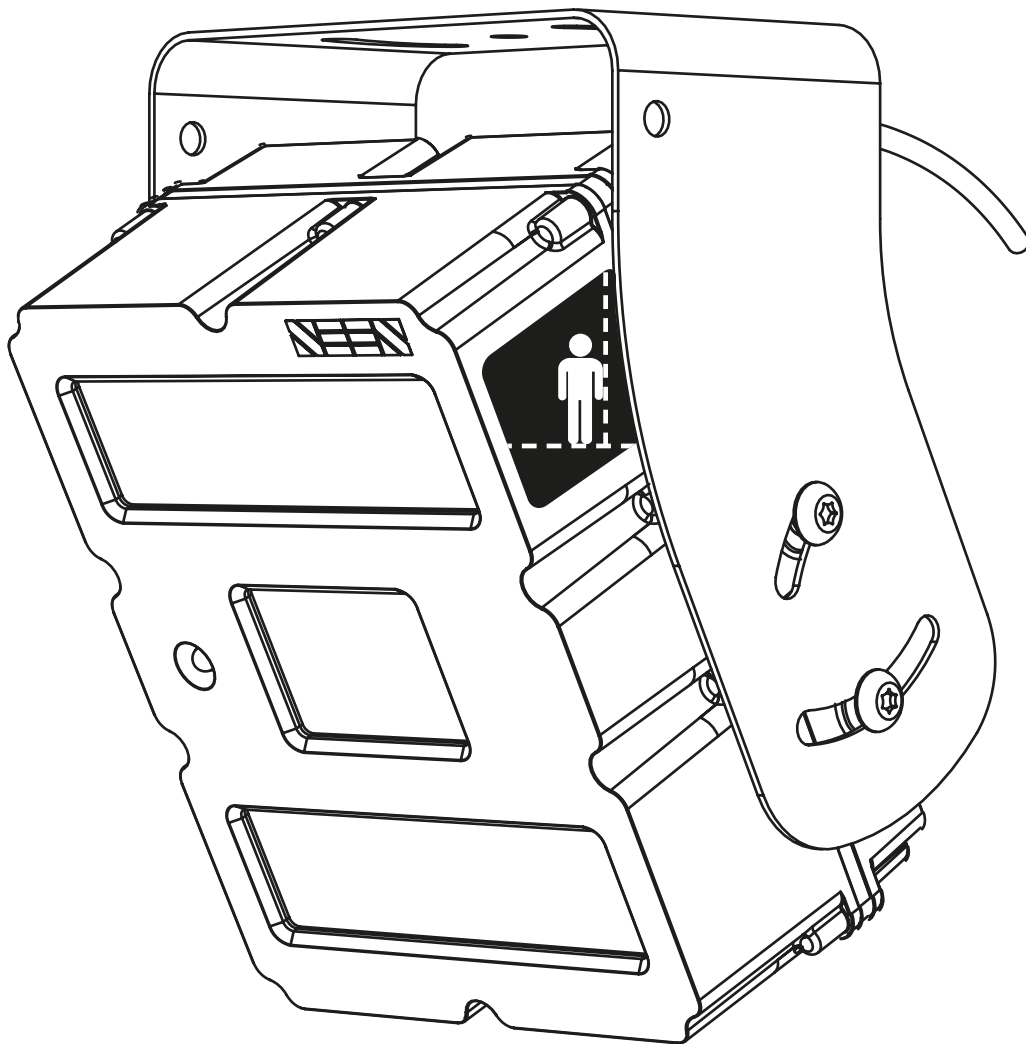

## Important

SEEN IRIS 860 sensors can provide collision warning assistance to the operator but do not replace the need for proper operator training and best practice safe operating procedure. While IRIS 860 sensors can alert the machine operator to a potential collision, the operator is always fully responsible for the safe operation of the equipment. IRIS 860 sensors do not comply with the regulatory standards required for devices which are intended to directly control vehicle or machine safety functions. Using the sensor accessory port to control a vehicle or machine function is entirely your own risk. Detection can never be guaranteed.

IRIS 860 sensors are a CLASS I LASER PRODUCT. Disassembly or modification of this device may result in hazardous radiation exposure.

IRIS 860 sensors and accessories have no user serviceable parts. Opening the enclosure will void the warranty.

This installation and set-up guide has been prepared with all due care and attention, however, Seen Safety Limited cannot be held responsible for any errors or omissions in this guide or any consequences thereof.

Seen Safety Limited  
www.seensafety.com  
support@seensafety.com

## Contents

<b>Before you start</b>	<b>3</b>
<b>System overview</b>	<b>3</b>
<b>Power requirements</b>	<b>4</b>
<b>Sensor mounting</b>	<b>6</b>
<b>Sensor wiring</b>	<b>7</b>
<b>Cab Box wiring</b>	<b>8</b>
<b>Cab Box Sensor Cable</b>	<b>10</b>
<b>Weather Shield</b>	<b>11</b>
<b>Set-up examples</b>	<b>12</b>
<b>Internal self check function</b>	<b>14</b>
<b>Sensor maintenance</b>	<b>14</b>
<b>Trouble-shooting</b>	<b>15</b>
<b>Connecting an accessory</b>	<b>17</b>
<b>Changing the sensor settings</b>	<b>19</b>
<b>Software settings</b>	<b>21</b>
<b>Warranty</b>	<b>22</b>
<b>Specifications</b>	<b>23</b>

# Before you start

Read this guide in full before starting installation. Incorrect installation may void the warranty. If you need help, contact your supplier or Seen Safety customer support by emailing [support@seensafety.com](mailto:support@seensafety.com)

## System overview

SEEN IRIS 860 sensors are intended for use on heavy mobile equipment like forklifts and wheel loaders. The sensor uses non-visible infrared laser light to detect the presence of retroreflective material such as the retroreflective tape found on day/night high visibility safety clothing and markers.

Each sensor has a 60° horizontal by 45° vertical field of view and can detect retroreflective material between 0.8m and 8.0m / 2.6ft and 26ft from the sensor face. Detection is indicated by a loud continuous-tone audible alert.

Sensor settings such as detection distance can be pre-set using SEEN's IRIS 860 setup app.

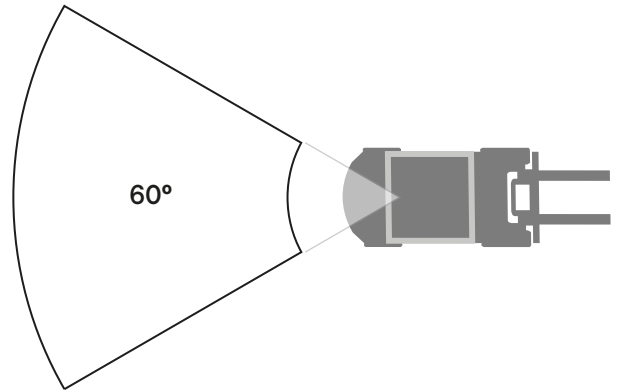
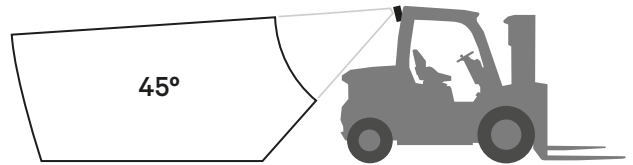
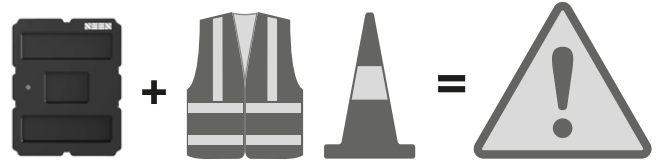

IRIS 860 sensors and Cab Boxes require a 12–24 volt power supply. Power supplies exceeding 24 volts require a DC/DC voltage reducer.



## IRIS 860 sensor

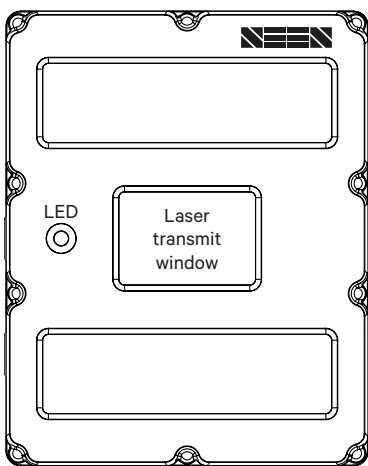

Front

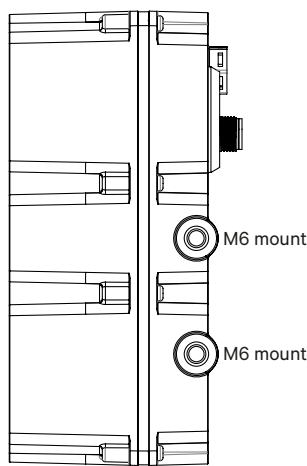

Side

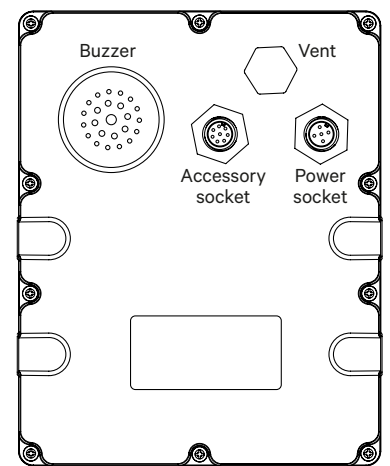

Back

# Power requirements

**IRIS 860 sensors and Cab Boxes require a 12–24 volt power supply. Power supplies exceeding 24 volts require a DC/DC voltage converter.**

## If voltage reduction is required

Use a DC/DC converter:

- Suitable for use on automotive equipment
- Rated to the machine's power supply voltage
- Output 12 or 24 volts at 2 amps. (Use a 5 amp converter if using a Cab Box with multiple sensors plus accessories.)

### Option 1: Use a non-isolated DC/DC converter

Sensor or Cab Box power cable

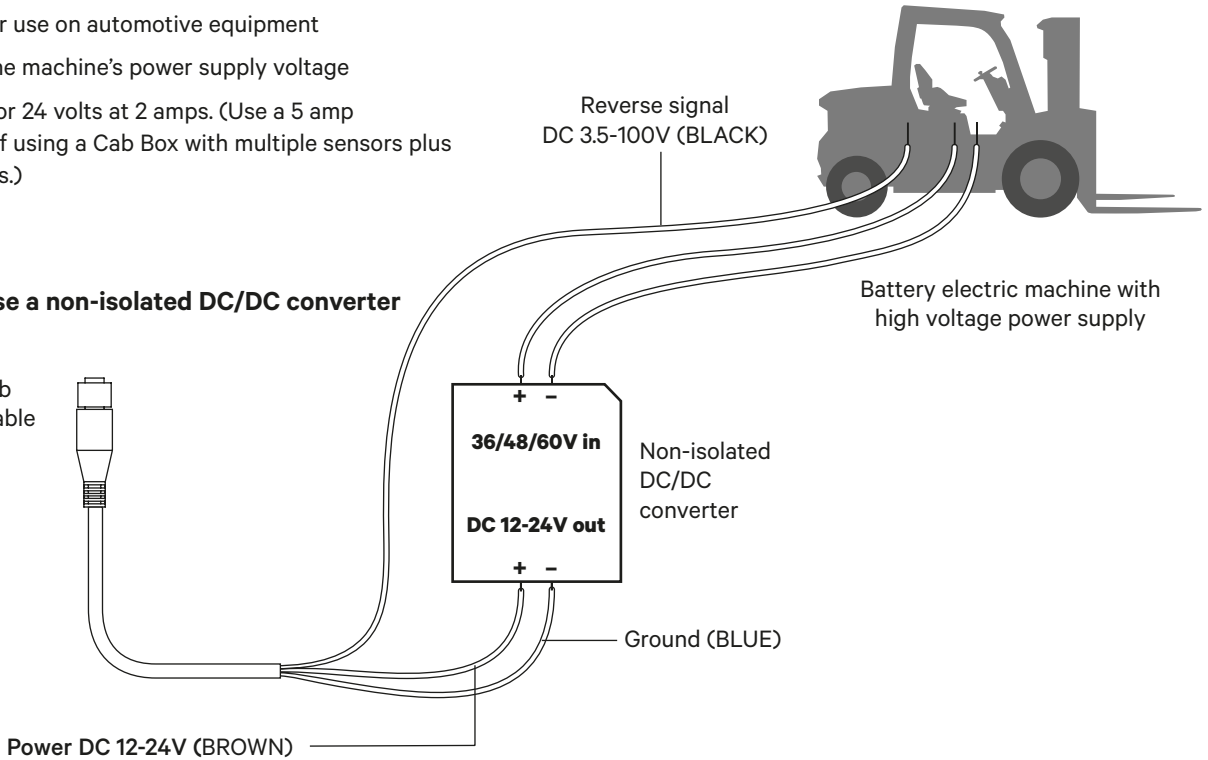

### Option 2: Use an isolated DC/DC converter with a bridge

Isolated converters can be bridged as shown in the diagram opposite. Bridging is required because the reverse signal input is electrically isolated from the IRIS 860 sensor ground (-V in) meaning the reverse signal is not grounded.

If the reverse signal does not share the same ground reference as the sensor (or Cab Box), the sensor will not receive the reverse signal and will not alert as expected.

A bridge across the DC/DC converter isolation barrier (as shown by the dashed line) is required so that both circuits share a common ground.

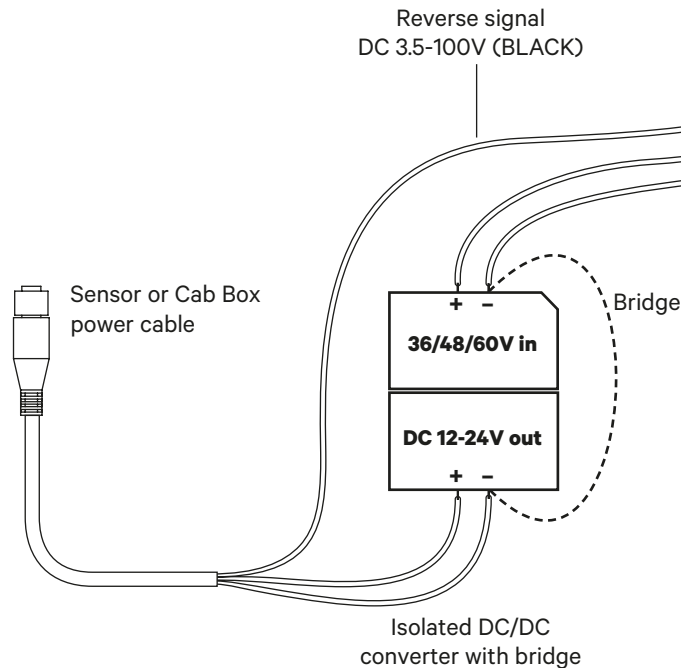

**WARNING.** If another accessory shares the DC/DC converter and requires an isolation barrier for safety, use a separate DC/DC converter or use a relay (see page 5).

### Option 3: Use an isolated DC/DC converter with a relay

When using an isolated DC/DC converter without a bridge, the reverse signal will not share the same ground reference as the sensor (or Cab Box), and the sensor will not receive the reverse signal. This may lead to unexpected behaviour.

To overcome this a relay must be added as shown in the diagram below. The relay should be:

- Suitable for automotive use
- Rated to the voltage of the reverse signal input
- Include a flywheel diode for protection.

When active, the relay allows the isolated supply voltage to appear on the reverse signal input to the sensor.

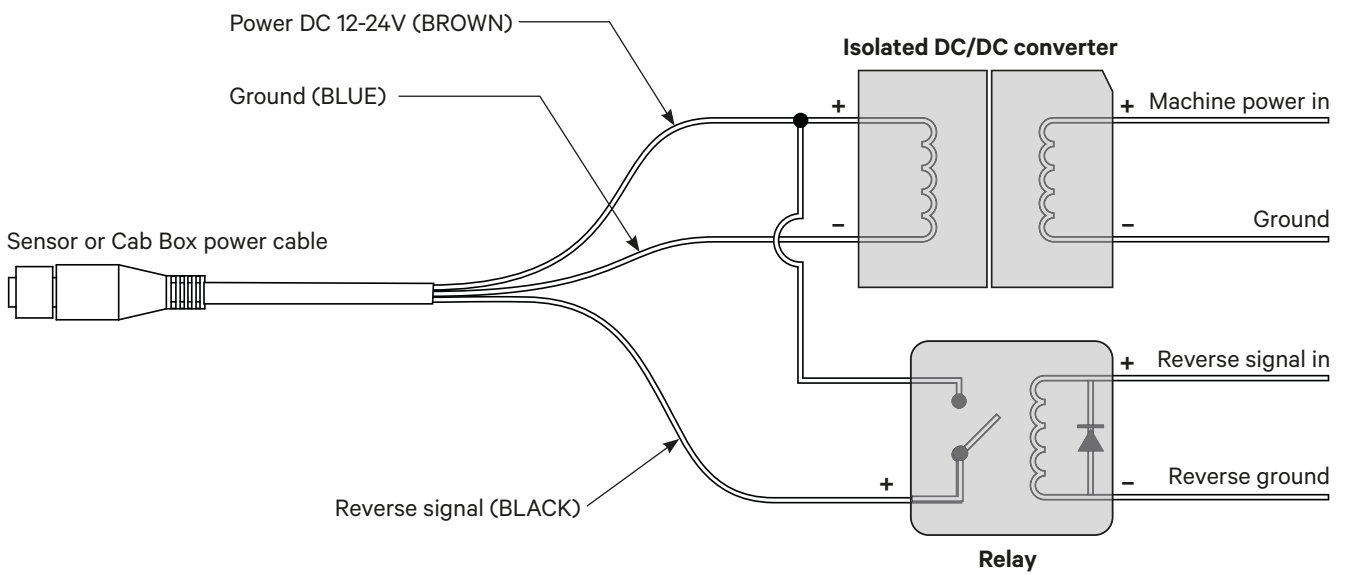

# Sensor mounting

The supplied stainless steel mounting bracket can be used on horizontal, vertical, or angled surfaces. The sensor should be mounted approximately 2 metres / 6-7 feet above the ground.

1. Choose mounting option A, B, or C as shown below.
2. Noting the required bracket orientation relative to the sensor, securely attach the bracket to a solid surface using appropriate M6 fasteners and torque settings.
3. Mount the sensor in the bracket as shown in the diagram. Finger-tighten the four M6 screws (supplied) to hold the sensor in the bracket. Adjust the sensor to the correct angle using the sticker as a guide. (Refer to page 11 if using a Weather Shield.)
4. Tighten the four M6 mounting screws to a maximum of 10Nm.

**Note.** An additional custom mounting plate may be required to mount the IRIS 860 bracket in the required location.

**WARNING.** Do not drill into any roll-over or falling-object protection structure (ROPS / FOPS) as this may compromise the strength of the structure and void the machine warranty.

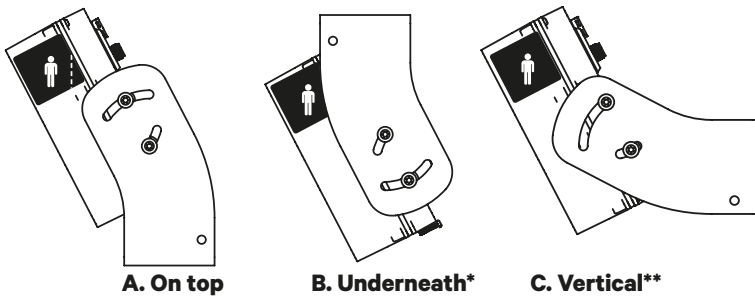

**Correct angle**

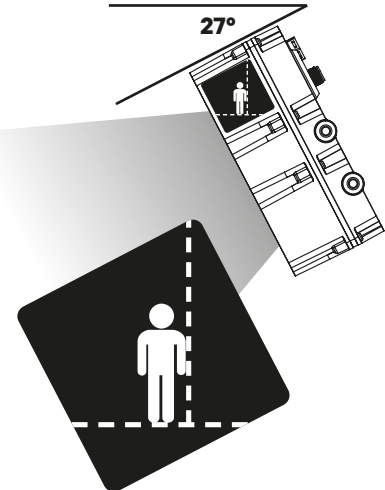

**The sticker indicates the correct angle**

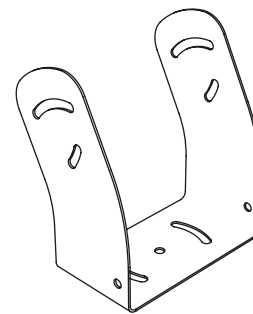
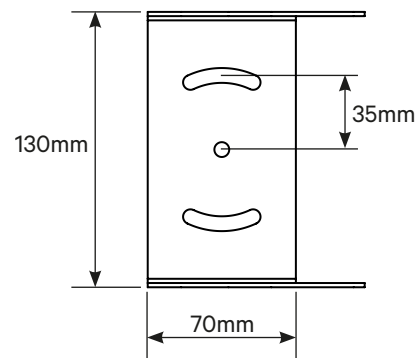

\*Not compatible with a Weather Shield. Refer to page 11.

\*\*The vertical mount option may not be suitable for installations where multiple sensors are used because the sensor bracket cannot be rotated to the required angle. Refer to page 13.

## Alert volume

The 94dB alert may be uncomfortably loud if the sensor is mounted close to the operator's head. Options:

- Consider a Top Mount instead of an Underneath Mount.
- Set the sensor to Reduced Volume in the IRIS 860 setup app.
- Use SEEN's snap-on volume reduction cap accessory.



# Sensor wiring

IRIS 860 sensors and Cab Boxes require a 12–24 volt power supply. Power supplies exceeding 24 volts require a DC/DC voltage reducer.



- If using a Cab Box skip to page 8.
- Use a voltage reducer if the supply voltage is greater than 24 volts. Refer to pages 4 and 5.
- The direction signal input (usually reverse) can be up to 100V.
- Follow the machine manufacturer instructions for connecting a third-party accessory.

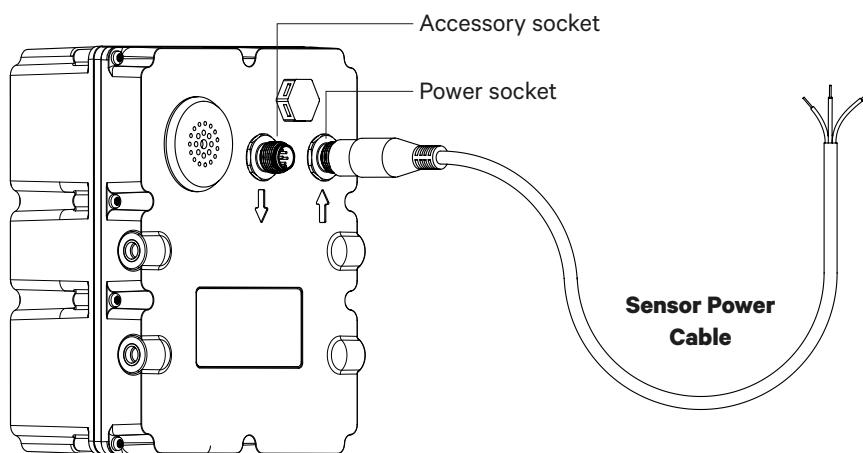
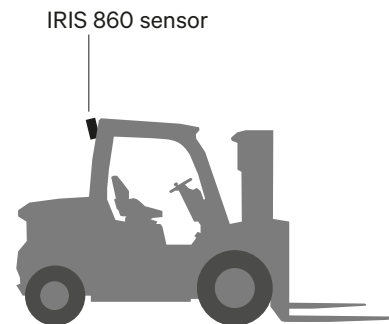

IRIS 860 sensor

- BROWN**  
Power (ignition)  
DC 12-24V ∓ 0.7A
- BLUE**  
Ground
- BLACK**  
Reverse signal  
DC 3.5-100V ∓ 1mA

Sensor Power Cable (5 pin)

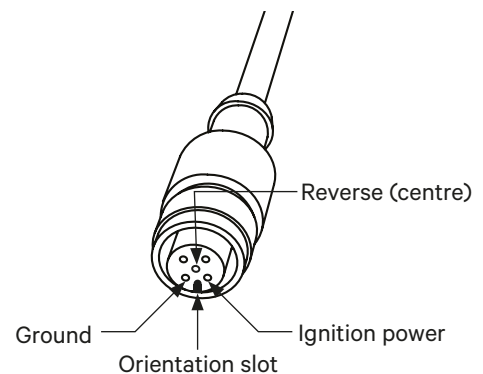

## Correct functionality

- **Power on** > Green LED and single beep followed by red LED flash (to indicate the sensor has booted) then steady green LED.
- **Detection** > Red LED and continuous audible alert.
- **Pre-alert** (if set) > Flashing Red LED and beeping audible alert.

## Direction Dependent Alert

By default IRIS 860 sensors are pre-set so they can only alert if they are receiving a direction signal (usually reverse) from the machine. This direction dependent setting can be changed in the IRIS 860 setup app.

## Cab Box wiring

A Cab Box is used on closed-cab machines to provide an audible detection alert and LED indication inside the cab. Up to four IRIS 860 sensors can be connected to each Cab Box.

A Cab Box Sensor Cable is used to connect each sensor to the Cab Box. These cables are available in 5m, 10m, or 15m (16ft, 33ft, or 50ft) lengths.

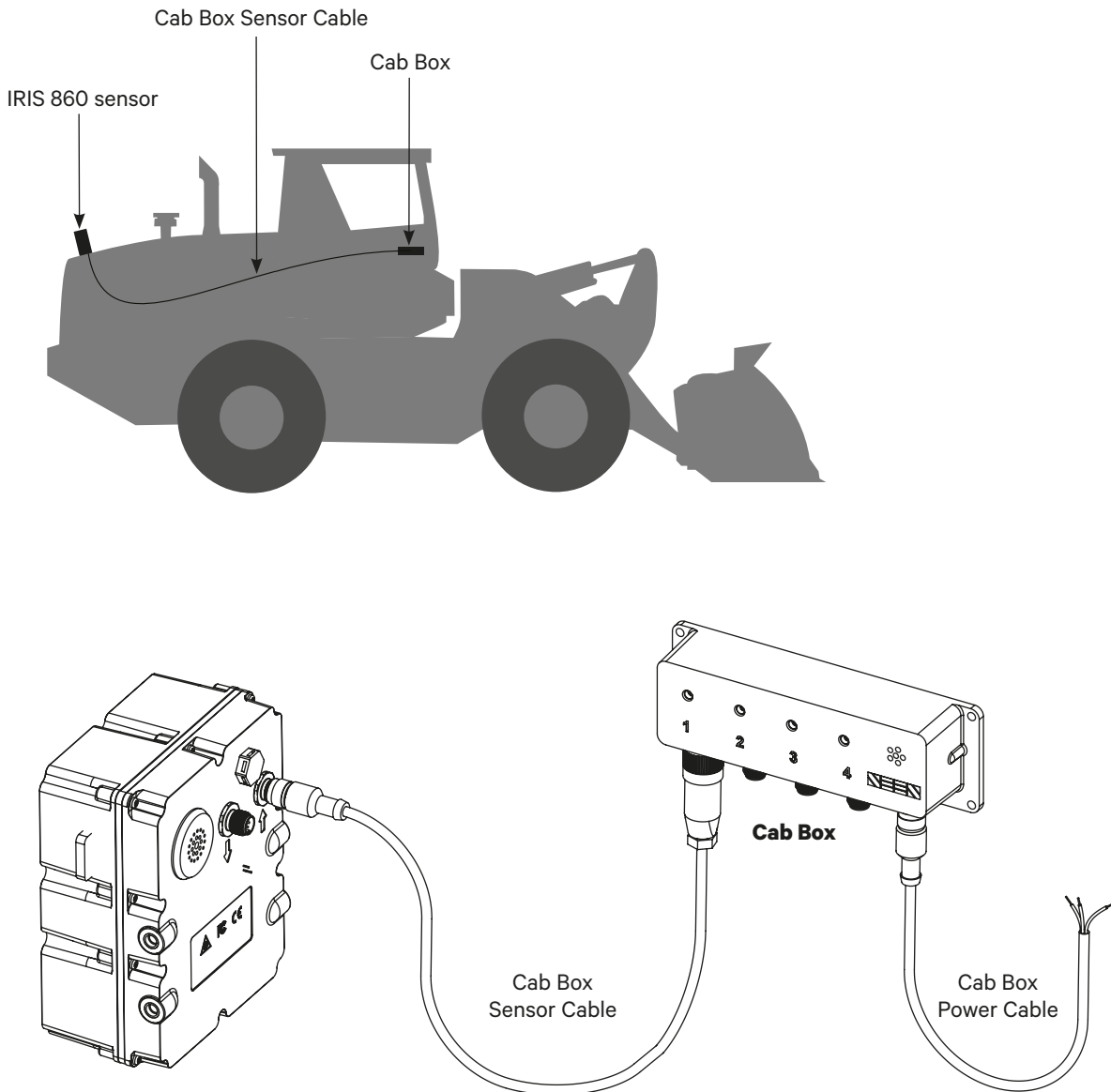



## Cab Box Power Cable

IRIS 860 sensors and Cab Boxes require a 12–24 volt power supply. Power supplies exceeding 24 volts require a DC/DC voltage reducer.



**Note.** The 5-pin sensor power cable supplied with each sensor is not required and should NOT be used.

- Use a voltage reducer if the supply voltage is greater than 24 volts. Refer to pages 4 and 5.
- The reverse signal input can be up to 100V.
- Follow the machine manufacturer instructions for connecting a third-party accessory.

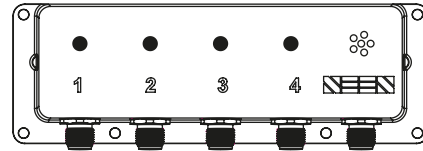

4 pin Cab Box power socket

### **BROWN**

Power (ignition)  
DC 12-24V  $\approx$  4.0A

**BLUE**  
Ground

**BLACK**  
Reverse signal  
DC 3.5-100V  $\approx$  1.0mA

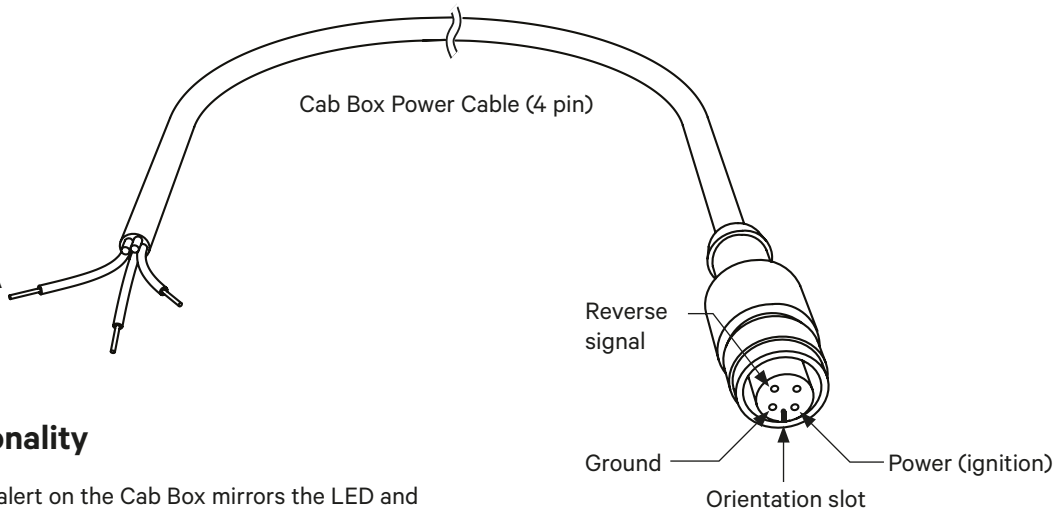

## Correct functionality

The LED and audible alert on the Cab Box mirrors the LED and audible alert on the connected sensor.

- **Power on** > Green LED and single beep followed by red LED flash (to indicate the sensor has booted) then steady green LED.
- **Detection** > Red LED and continuous audible alert.
- **Pre-alert** (if set) > Flashing Red LED and beeping audible alert.

## Direction Dependent Alert

By default IRIS 860 sensors are pre-set so they can only alert if they are receiving a direction signal (usually reverse) from the machine via the Cab Box. This direction dependent setting can be changed in the IRIS 860 setup app.

# Cab Box Sensor Cable

Cab Box Sensor Cables are used to connect the sensor to the Cab Box. They are available in 5, 10, and 15 metre (16, 33, 50 foot) lengths. One end of the cable has a re-wireable plug that can be removed to assist the threading of the cable through the machine chassis or to shorten the cable. When re-attaching the plug check that the wire colours match the diagram below. Use the screw-block as a reference.

**Note.** The re-wireable plug should be connected to the Cab Box to protect it from the elements. The moulded end should be connected to the sensor.

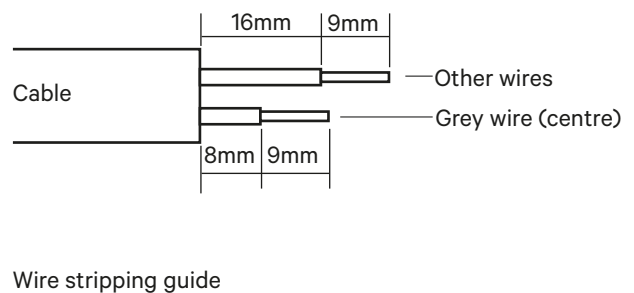
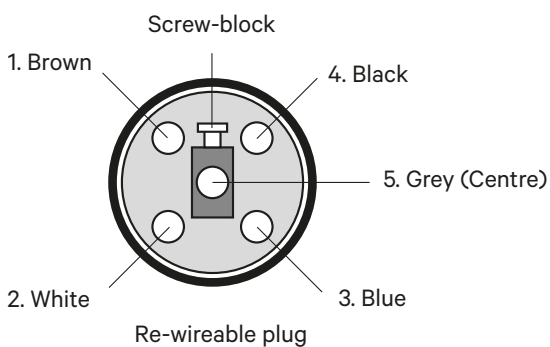
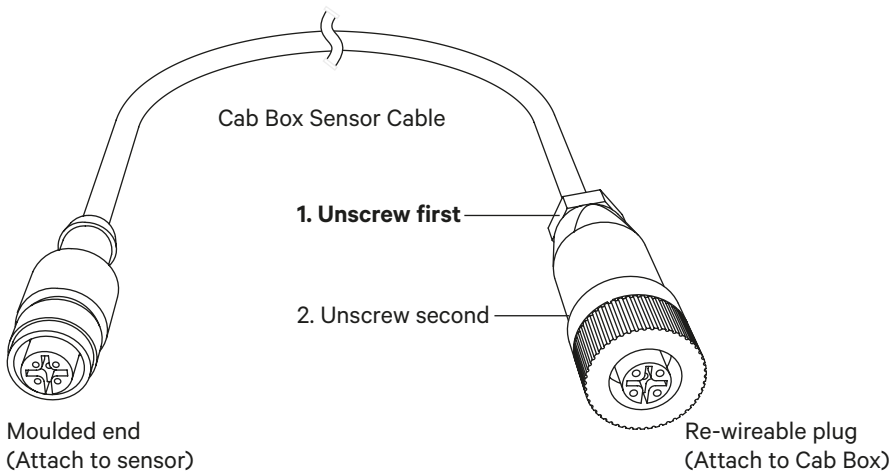

# Weather Shield

A Weather Shield (P/n SI-115) helps protect the sensor from rain, heat and UV.

**Note.** It is not possible to attach a Weather Shield to a sensor mounted in the 'Underneath' position.

## Step 1

Before installing the Weather Shield, gently tighten **screw A** on both sides to hold the sensor in the bracket at the correct angle.

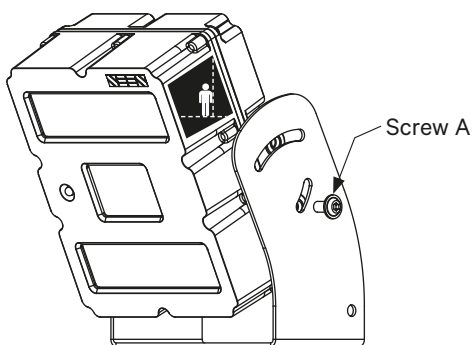

## Step 2

Place the Weather Shield over the sensor and bracket so that the round holes in the Weather Shield fit over **screw A** on both sides.

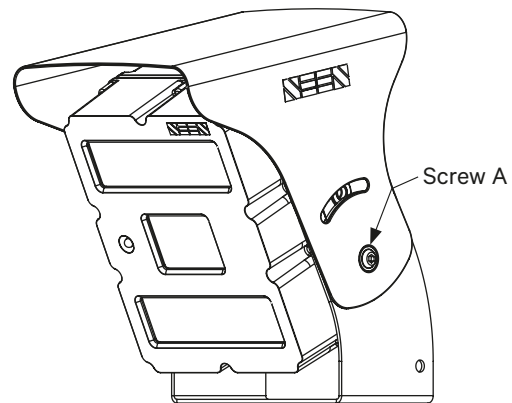

## Step 3

Insert **screw B** on both sides. Check the alignment and evenly tighten the four M6 mounting screws to maximum 10Nm.

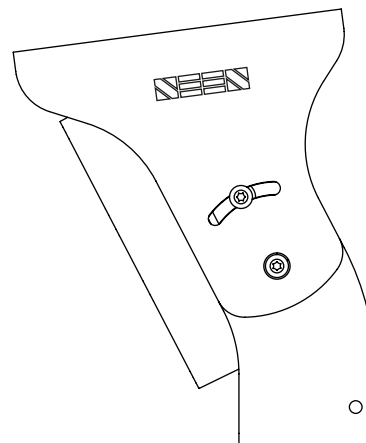
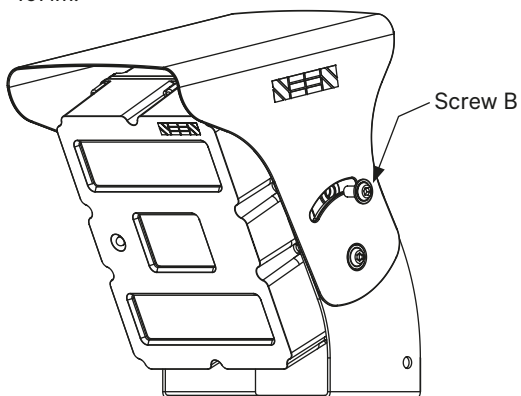

## Set-up examples

### Forklift

- 1 or 2 sensors on the top-rear of the machine
- 3m / 10ft critical alert zone
- 1m / 3.3ft pre-alert zone
- Sensor set so to only alert in reverse

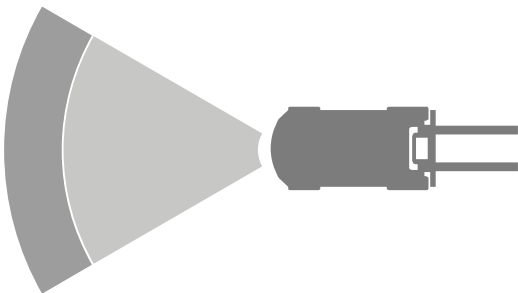

- Critical alert zone = continuous audible alert
- Pre-alert = beeping audible alert

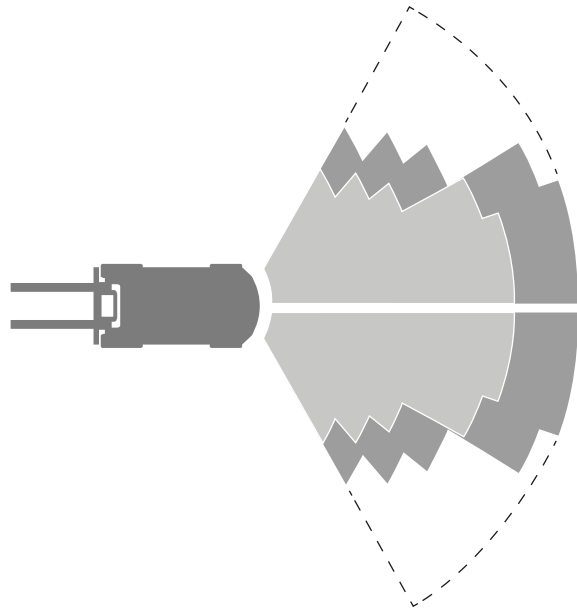

A customised detection zone can help to minimise non-critical detections

**Note.** The scenarios shown above are examples only. Your specific requirements may differ.

### Wheel-loader

- 1 or 2 sensors on the back of the machine mounted above the radiator
- A Cab Box inside the cab with cables connected back to each sensor
- 5m / 16ft critical alert zone
- 1.5m / 5ft pre-alert zone
- Sensor set to only alert in reverse

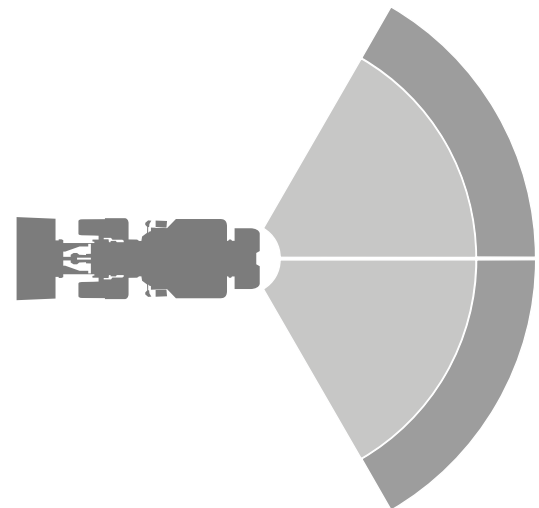
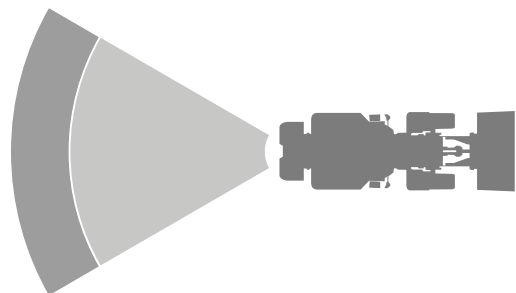

## Two sensors mounted side-by-side

When two sensors are mounted side-by-side, the sensor brackets should be spaced approximately 160mm / 6" apart and rotated approximately 20° outwards. The combined field-of-view is around 100-105° depending on the amount of overlap.

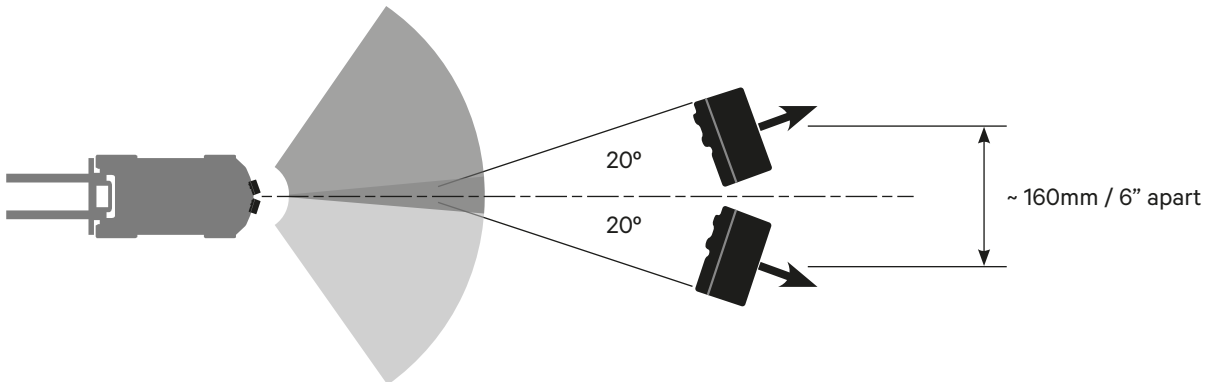

## Two sensors mounted crossed-over

Compared to the side-by-side mounting option, the crossed-over mounting option offers improved detection zone overlap close to the machine, reduces the 0-0.8m/2.6ft no-detection zone, and increases the overall field-of-view.

The sensor brackets should be spaced approximately 1m / 3ft apart (about the width of a forklift cab / wheel loader engine) and each bracket should be rotated approximately 30-35° inwards. The combined field-of-view is around 120-130° depending on the amount of overlap.

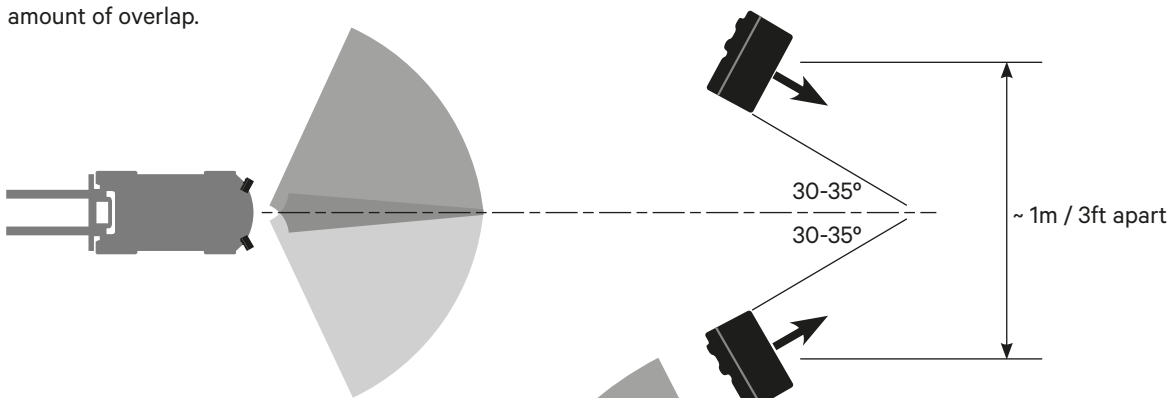

**CHECK.** In either option, both sensors should simultaneously detect a person standing in the center of the detection zone at the maximum and minimum detection range.

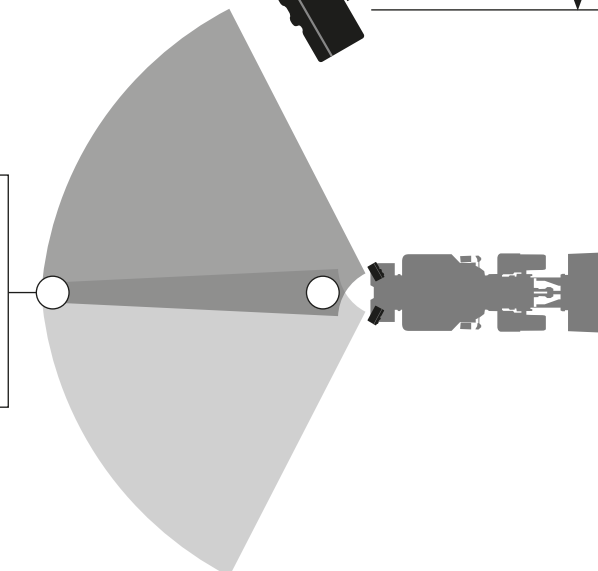

## Internal self check function

IRIS 860 sensors have an automatic internal self-checking function. If a fault is detected the sensor (and Cab Box if used) will flash and beep a pattern indicating the type of fault detected.

### Window contamination dust/dirt

Situation: The sensor operates in a dusty or dirty environment

Problem: The sensor windows are excessively contaminated.

Indication: Continuous beep and flash sequence long-short-short, long-short-short etc. --- --- --- ---

Solution: Clean the sensor windows

### Window contamination ice/condensation

Situation: The sensor operates in a cold store / freezer environment.

Problem: Ice or condensation on the windows is triggering the window self check test.

Indication: Beep and flash sequence long-short-short, long-short-short etc. --- --- --- ---

Possible solution: First check whether pedestrian workers can be reliably detected with ice or condensation present on the windows. If detection is reliable, then the window self check function may be turned off using the setup app. **Use this setting with caution** because the window self-check function will be disabled. Contact SEEN customer support for more information.

### Sensor internal fault

Any error sequence that is NOT long-short-short, long-short-short indicates an internal fault. Unplug the sensor and contact your reseller or supplier to arrange repair or replacement.

**IRIS 860 sensors have no user-serviceable parts.**

## Sensor maintenance

**IRIS 860 sensors have no user-serviceable parts.**

Other than keeping the windows and buzzer free of dust and dirt, no scheduled maintenance is required.

Remove dust and dirt using clean water and a clean non-abrasive cloth.

**Do not use high pressure water jets to clean.**

**Do not use chemical cleaners including alcohol, benzene, thinners, and degreasers.**

**Opening the enclosure will void the warranty.**

## 1. The sensor LED is green, but the sensor will not alert.

**Possible cause 1:** The sensor is pre-set so it can only alert while receiving a direction signal (usually reverse) from the machine, but the reverse signal has not been connected.

**Solution:** Ensure that the 3 wires on the sensor (or Cab Box) power cable are correctly wired to the machine's reverse signal, power, and ground.

**Possible cause 2:** The retroreflective test target is too close to the sensor.

**Solution:** Move further back. Detection starts 0.8m /2.6ft from the sensor face.

## 2. A sensor pre-set so that it can only alert during reverse, can also alert when not in reverse.

**Possible cause:** The reverse signal input wire is twisted together with the ignition power wire, meaning the reverse signal is always high.

**Solution:** Ensure that the 3 wires on the sensor (or Cab Box) power cable are correctly wired to the machine's reverse signal, power, and ground.

## 3. The sensor and/or Cab Box are correctly wired but the sensor/s do not behave in the expected way.

**Possible cause:** Electrical earthing issue on the reverse signal.

**Solution:** Check that the ground reference on the reverse signal is the same as the ground reference on the sensor power supply. Refer to page 16.

## 4. The Cab Box is correctly wired but the sensor/s do not behave in the expected way.

**Possible cause:** Wrong power cable.

**Solution:** Use the 4 PIN Cab Box power cable supplied with the Cab Box. Do not use the 5 PIN sensor power cable supplied with each sensor.

## 5. The sensor repeatedly beeps and flashes with the sequence long-short-short, long-short-short.

**Cause:** Blocked window.

**Solution:** Clean the windows and the self-check alert should cease. If the sensor is operating in a cold-store freezer, ice on the window maybe triggering the self checking function. Refer to the Internal Self Check section on page 14.

## 6. The sensor is beeping and flashing and the sequence is NOT long-short-short, long-short-short.

**Cause:** Internal fault detected.

**Solution:** There are no user serviceable parts. Contact your supplier for repair or replacement.

**7. A sensor with a connected accessory will not power up when using the USB config cable.**

**Cause:** The USB port cannot supply sufficient power.

**Solution:** Unplug the accessory from the sensor before connecting the USB config cable.

**8. At start-up the sensor gives a continuous tone alert when the vehicle is in gear.**

**Cause:** Test Mode may be enabled and has been inadvertently activated. Refer to page 21.

**9. Direction signal grounding issue.**

Applies to a sensor or Cab Box connected to a direction signal input (usually reverse). **If a DC/DC converter is used refer to pages 4 and 5.**

Note: In this example the direction signal is REVERSE.

**Problem:** The sensor (or Cab Box) is correctly powered and connected to the reverse signal, but the sensor does not alert, even when the reverse signal is active.

**Possible cause:** The reverse signal and sensor power supply may not share a common ground.

To check the reverse signal ground:

- Unplug the sensor or Cab Box power cable
- Switch the vehicle ignition ON (preferably without starting the vehicle for safety)
- Attach a voltmeter across the ignition power pin (+) and the ground pin (-) of the power cable. The voltage should be between +10V and +29V. Refer to the plug diagrams opposite.
- Next, attach the voltmeter across the reverse direction pin and the ground pin (-). When the vehicle is NOT in reverse, the voltage should measure between 0V and +1V. When the vehicle IS in reverse it should measure between +3V and +100V.

If the vehicle is in reverse and the voltage is not 3-100V between the ground pin (-) and the reverse direction pin, there may be a grounding issue.

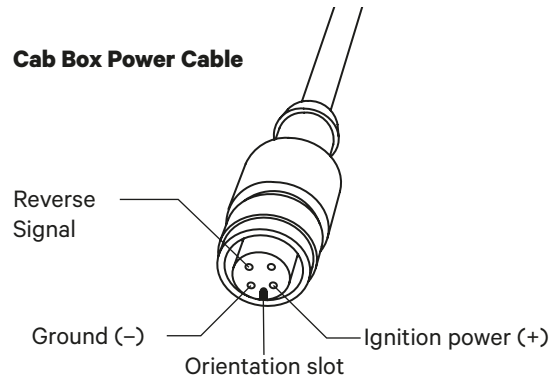
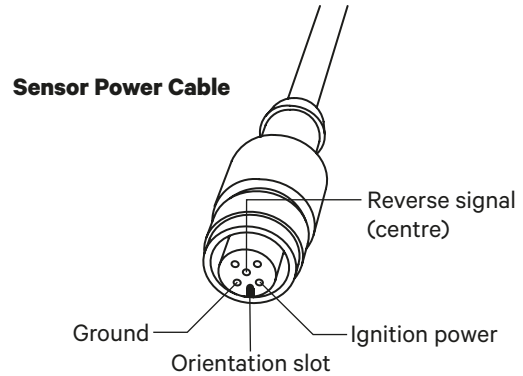



# Connecting an accessory

The 8-pin M12 accessory socket outputs an electrical signal while the IRIS 860 is detecting. The signal output behaviour can be controlled in the IRIS 860 setup app. By default the detection signal output is only high during a detection in the Critical Alert zone.

## Accessory Cable

The IRIS 860 Accessory Cable (P/n SI-121) can be used to connect a third-party accessory such as a camera or light.

**IMPORTANT.** The Accessory Cable is for the IRIS 860 sensor only. Do not attach the Accessory Cable to a Cab Box.

Pin no.	Wire colour	Description
1	Brown	12V accessory power supply
2	White	Ground / Earth
3	Blue	Detection NPN
4	Black	Detection 3.6V logic output
5	Grey	Do not connect
6	Pink	Detection 12V logic output

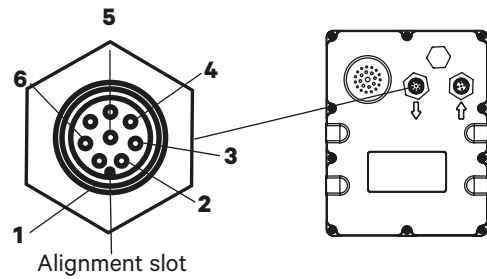

**Note.** Refer to the accessory socket pin-out diagram on page 24 for the complete specification.

## Accessory use-case examples

### External buzzer or light

On detection the NPN transistor switch closes putting 12V across the connected accessory. The maximum supply current is 500mA.

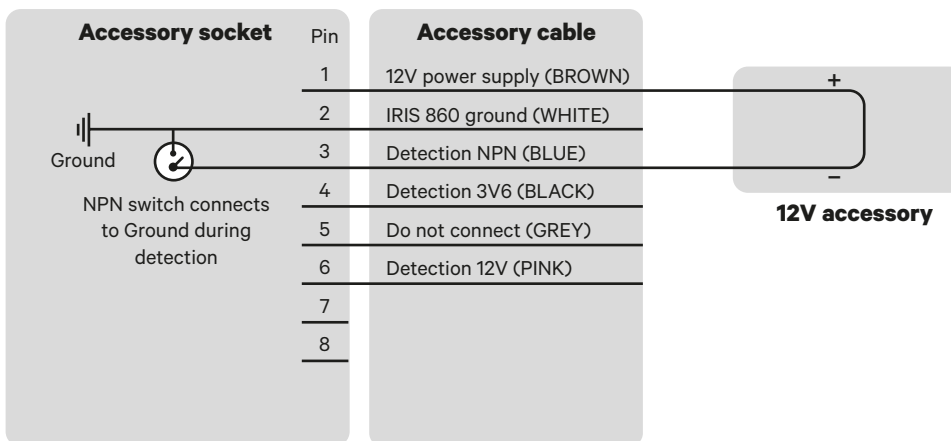

## External relay

On detection the NPN transistor switch closes putting 12V across the relay. A flywheel diode is required across the relay coil to protect the NPN transistor against the coil transient when the detection event ends and the coil is switched off.

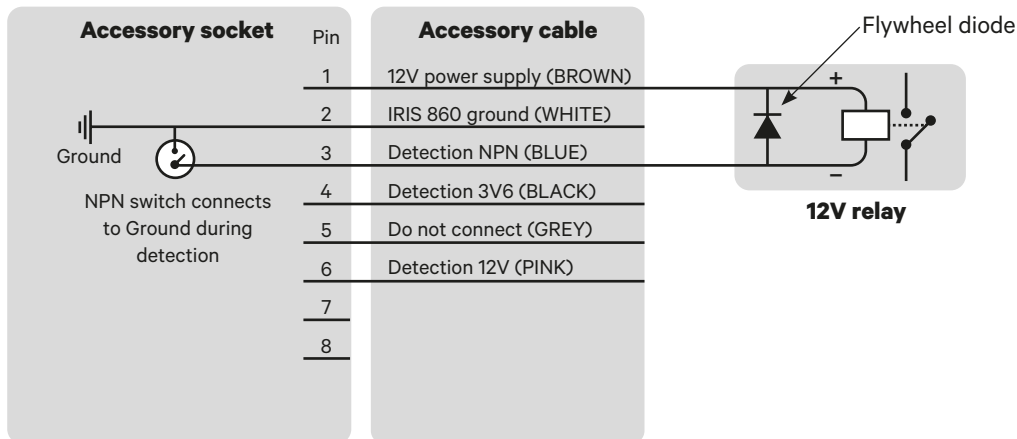

## Camera with digital input

The IRIS 860 accessory power supply is used to power the camera accessory (maximum supply current 500mA). Detection 12V puts 12V on the camera trigger during detection. This is a low power output and can only supply a few milliamps of current. If required, add an external regulator to limit the 12V detection logic output voltage (e.g. down to 5V or 3.3V) or use Detection 3V6 (black) for a 3.6V detection output.

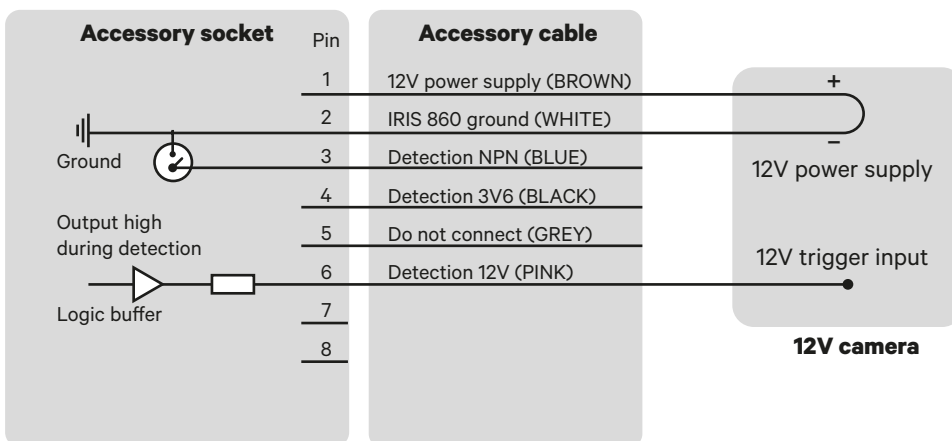

# Changing the sensor settings

## Requirements

- IRIS 860 sensor
- IRIS 860 USB Config Cable P/n SI-122
- SEEN's free IRIS 860 setup app
- A Windows computer with a USB port, or an OTG compatible Android smart phone or tablet

## You may also need

- A USB OTG adapter\*
- An IRIS 860 USB Config Cable to Sensor Cable Adapter P/n SI-124

\*An OTG or On The Go adapter (sometimes called an OTG cable, or OTG connector) allows you to connect a full sized USB-A cable to your phone or tablet through the Micro USB or USB-C charging port. These adapters are available from technology retailers.

## Device compatibility

- Not all smart phones and tablets are USB OTG compatible
- Non OTG compatible devices cannot support USB serial communications and will not connect to the sensor
- Some OTG compatible smart phones and tablets will not supply sufficient power to the sensor
- **Check your device can connect to an IRIS 860 sensor BEFORE going on site.**

**Note.** SEEN have tested and recommend the LENOVO Tab M8 HD P/n TB-8505F tablet to provide reliable connection. (This tablet requires a USB OTG Micro USB adapter.)

**Note.** If the sensor has an accessory attached, remove the accessory prior to attaching the USB config cable. The accessory may draw more power than the USB plug can supply and the sensor will not power on.

## Software

**Download IRIS 860 setup app at**  
**[www.seensafety.com/download](http://www.seensafety.com/download)**

## USB connection

### Direct to sensor

- Launch the SEEN IRIS 860 setup app
- Connect the IRIS 860 sensor to the computer or Android mobile device using an IRIS 860 USB Config Cable (OTG compatible smart phones or tablets will require a USB OTG adapter)
- Wait a few seconds for the sensor to power up and boot (indicated by red LED flash then steady green)
- The sensor LED will glow green when powered on
- Follow the on-screen instructions.

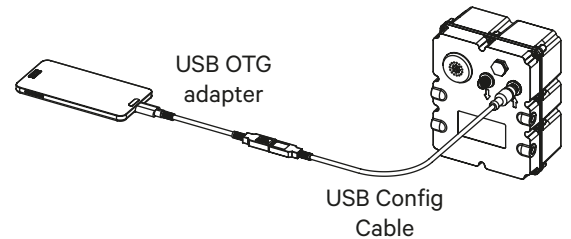
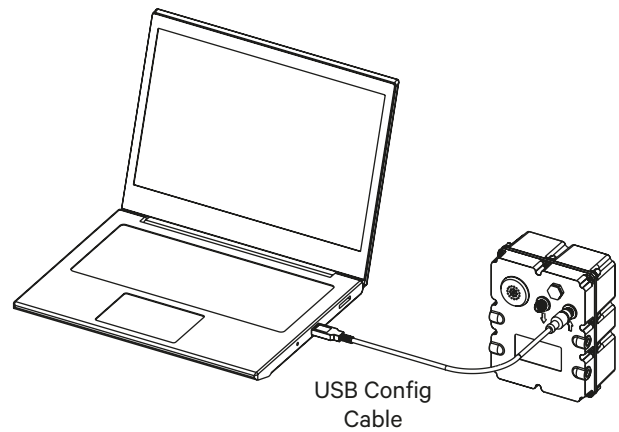

### Via the Cab Box Sensor Cable

If direct access to the sensor is difficult, the USB config cable can be connected to a Cab Box Sensor Cable from inside the cab. This requires an IRIS 860 Cable Adapter (P/n SI-124)

- Launch the SEEN IRIS 860 setup app
- Unplug the relevant Cab Box Sensor Cable from the Cab Box and plug it into the Cable Adapter
- Attach the Cable Adapter to the USB Config Cable
- Plug the USB plug into the USB port on the computer or Android mobile device. (For OTG compatible smart phone or tablet a USB OTG adapter will be required)
- Wait a few seconds for the sensor to power up and boot (indicated by red LED flash then steady green)
- Follow the on-screen instructions.

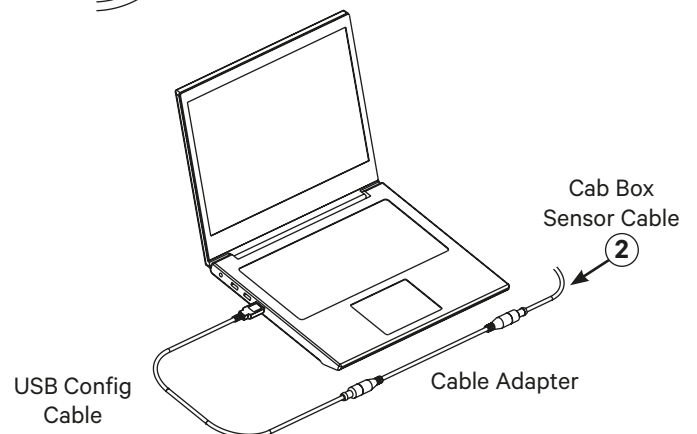
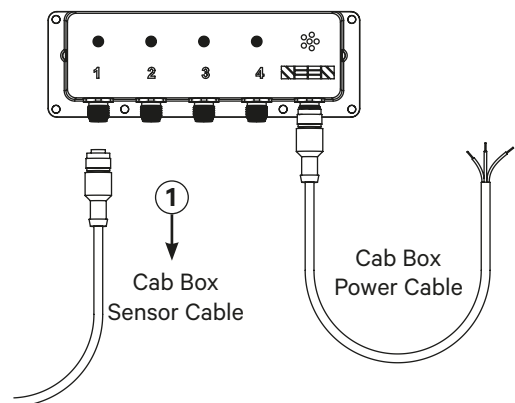

# Software settings

IRIS 860 sensor settings can be changed using SEEN's free setup app.

## Critical alert

A detection in the Critical alert zone is indicated by a continuous audible alert tone from the sensor (and Cab Box if used). The factory default setting is 4m / 13 ft.

## Pre-alert

A detection in the Pre-alert zone is indicated by a beeping audible alert tone. The factory default setting is 0m.

Note: The combined total of Critical alert distance plus Pre-alert distance cannot exceed 8.0m / 26ft.

## Direction Dependent Alert

Requires connection to the vehicle direction signal (e.g. forward or reverse). Options:

- Sensor can only alert when the direction signal is active
- Sensor can only alert when the direction signal is not active
- Sensor can always alert (direction signal is ignored)

## Volume

Options: **Normal** / Reduced / OFF

When Reduced is selected the alert volume is decreased from 94dB at 1 metre to approximately 86dB at 1 metre. This setting can be used in situations where the sensor is mounted close to the operators head and the alert is uncomfortably loud. OFF completely disables the audible alarm. **Use with caution.**

## Test Mode

Options: ON / OFF

If Test Mode is set to ON in the sensor setup software, the machine operator can temporarily toggle the sensor into 'test mode' where it will ignore the Direction Dependent Alert setting. This allows the operator to safely walk around the machine to test the sensor is detecting, without having to put the machine in reverse gear.

## Procedure

Turn the ignition on (to power the sensor), wait 2 to 5 seconds, then turn the ignition off. The next time the ignition is turned on the sensor will be toggled to Test Mode, indicated by a flashing green LED on the sensor (and Cab-Box if used).

Test Mode lasts 2 minutes. The green LED on the sensor (and Cab Box if used) flashes to indicate Test Mode is active.

The operator can check the sensors are working by walking into the detection zone wearing a reflective safety vest. Detection is indicated by an audible alert tone and red LED.

## Reverse/Direction signal check

This test ensures the reverse signal is correctly connected. While Test Mode is active, when the operator engages reverse gear, the audible alert should sound indicating the reverse signal is correctly connected.

Once the test is complete, turn the ignition off and restart the machine.

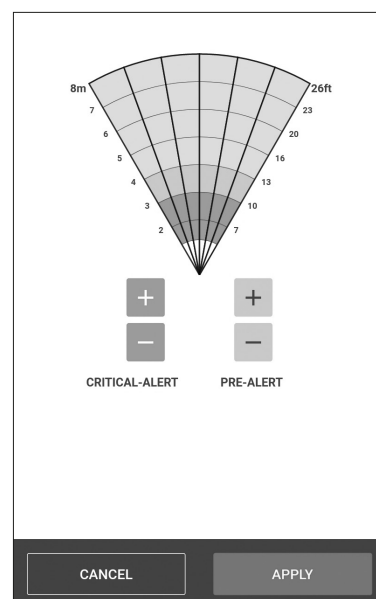
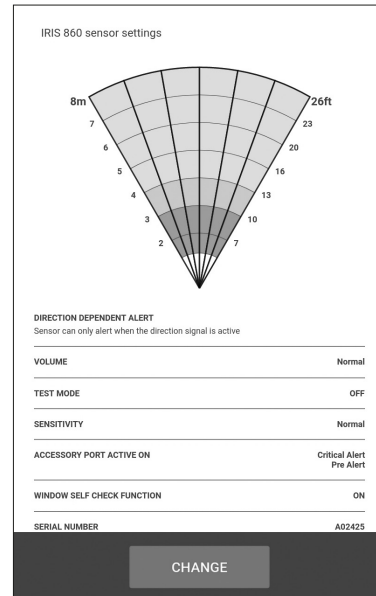

**Note.** To clear Test Mode at any time simply switch the ignition off, then re-start the machine.

### **Sensitivity**

Options: **Normal** / Reduced

When set to Reduced sensitivity the sensor requires approximately 30% more reflective material to detect than at Normal sensitivity. Reduced sensitivity can help in environments where false detections are observed. A false detection is any detection that does not come from a retroreflector. Although uncommon, the sensor may occasionally be triggered by plastic stretch-wrap and certain metallic surfaces which create a retroreflective type effect.

### **Accessory socket output**

Options: **Critical-alert** / Pre-alert / Internal error / Test mode

By default the accessory socket only outputs the detection signal on critical alert. The sensor can be set to also output an electrical signal on pre-alert, internal error, and to indicate that test mode is active.

## Warranty

### **IRIS 860 sensor**

IRIS 860 sensors have been designed for reliable long-term use on industrial vehicles in indoor or outdoor applications. The sensor is covered by a 2 year repair or replacement warranty on materials and workmanship. The warranty excludes general wear and tear, physical damage caused by direct impact to the sensor, over-tightening or misalignment of the M12 connectors, damage to the sensor windows, damage caused by high-pressure water jets, damage caused by chemical cleaners (including alcohol, benzene, thinners, and degreasers), or damage caused by over-voltage to the power supply. IRIS 860 sensors have no user serviceable parts.

**Opening the enclosure will void the warranty.**

### **IRIS 860 Cab Box**

The IRIS 860 Cab Box is covered by a 1 year repair or replacement warranty on materials and workmanship. The warranty excludes general wear and tear, physical damage caused by direct impact, damage caused by exposure to moisture, over-tightening or misalignment of the M12 connectors, or damage caused by over-voltage to the power supply.

# Specifications

## IRIS 860 sensor

Input power (ignition)	DC 12-24V $\approx$ 0.7A	Safety	Caution Class I LASER PRODUCT. Disassembly or modification of this device may result in hazardous radiation exposure
Direction signal input	DC 3.5-100V $\approx$ 1mA	Standards	IEC 61000-6-4 (EMC emissions) IEC 61000-4-2 (EMC immunity) IEC 60825-1:2014 (Laser eye safety) IEC 61010-2-201:2017 (Electrical equipment safety)
Power consumption	2.0W max (sensor only) 8.0W max (with attached accessories)	Lighting	Immune from sunlight interference or ambient lighting conditions.
Detection range	0.8m - 8.0m / 2.6ft - 26ft	Ingress protection	IP67
Detection area	60 degrees horizontal x 45 degrees vertical	Enclosure	ASA injection moulded plastic
Detection target	Class II day/night high visibility safety apparel / vest and other retroreflective material	Mounting	4 x M6 brass inserts
Latency	Minimum detection time: 0.05s Maximum detection time: 0.33s Median detection time: 0.19s	Windows	Hard coated IR filtered PMMA
Maintenance	No scheduled maintenance required	Weight	0.48 kg
Buzzer	94dB at 1m 3500Hz	Dimensions	125mm x 160mm x 85mm
Connectors	M12 5-pin and M12 8-pin	Operating temperature:	-20° to +60° C / -4° to +140° F ambient
Laser type	Pulsed infrared 905nm non-visible		

## IRIS 860 Cab Box

Input power (ignition)	DC 12-24V $\approx$ 4A	Ingress protection	None
Direction signal input	DC 3.5-100V $\approx$ 1mA	Enclosure	ASA injection moulded plastic
Power consumption	48W max (with 4 attached sensors and accessories)	Standards	IEC 61000-6-4 (EMC emissions) IEC 61000-4-2 (EMC immunity) IEC 61010-2-201:2017 (Electrical equipment safety)
Maintenance	No scheduled maintenance required. Keep buzzer clear	Weight	0.25kg
Buzzer	85 dB at 1m 2500Hz	Dimensions	178mm x 66mm x 38mm
Operating temperature:	-20° to +60° C / -4° to +140° F ambient		

Product specifications are subject to change without notice to improve reliability, function, design or otherwise.



Sensor label



Cab Box label

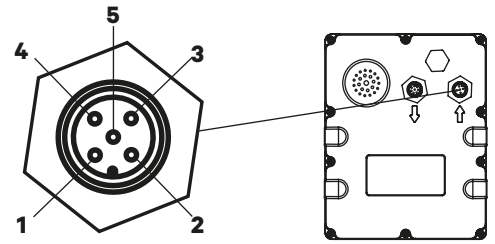

### IRIS 860 sensor power socket (M12 5-pin)

Pin	Name	Description	Direction	Max. input voltage	Min. input voltage	Input high voltage	Input low voltage	Output high voltage	Output low voltage	Conditions	Notes
1	Vin +	Power supply positive	Input	30v	10.8v	-	-	-	-	-	8W maximum power draw (with attached accessory). 2W maximum for sensor only
2	Vin -	Power supply negative (ground)	-	-	-	-	-	-	-	-	System / chassis ground
3	System status	High when sensor is operating	Output	-	-	-	-	5.2v max. 4.5v min.	0.1v max.	1K Ohm load to ground	PNP output
4	Detection	High when sensor detects	Output	-	-	-	-	5.2v max. 4.5v min.	0.1v max.	1K Ohm load to ground	PNP output
5	Direction	Reverse/direction signal input	Input	100v	0v	3.5v min.	1v max.	-	-	-	Input current is less than 1.0 mA

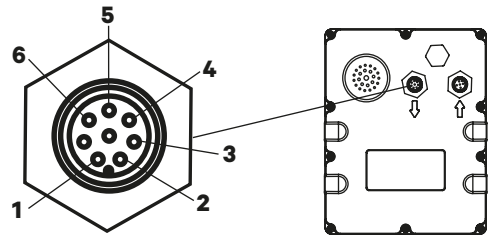

### IRIS 860 sensor accessory socket (M12 8-pin)

Pin	Name	Description	Direction	Max. input voltage	Min. input voltage	Input high voltage	Input low voltage	Output high voltage	Output low voltage	Conditions	Notes
1	12V out	Accessory power supply	Output	-	-	-	-	12.1v max. 10v min.	-	Supply voltage 12v and drawing 500mA from accessory supply pin	Used to power an external device
2	Vin -	Accessory supply negative (ground)	-	-	-	-	-	-	-	-	System / chassis ground
3	Detection NPN	Output during detection	Output	-	-	-	-	30v max.	0.8v max.	0.8v output low max when sinking 500 mA	NPN output, max blocking voltage 30v
4	Detection 3V6	Output during detection (low voltage logic)	Output	-	-	-	-	3.6v max. 2.0v min.	-	Source / sink 100 uA max.	-
5	Do not connect										
6	Detection 12V	Output during detection (high voltage logic)	Output	-	-	-	-	11v max. 9.3v min.	-	Supply voltage 12v, 2K Ohm load to ground	470 Ohm internal resistor in series with this output



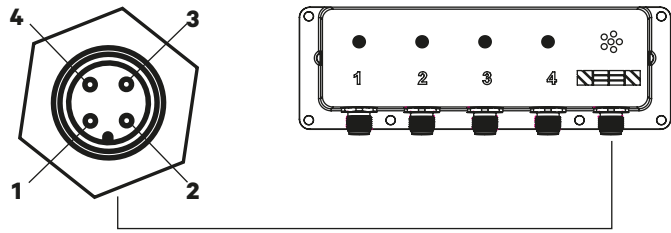

### Cab Box power socket (M12 4-pin)

Pin	Name	Description	Direction	Max. input voltage	Min. input voltage	Input high voltage	Input low voltage	Output high voltage	Output low voltage	Conditions	Notes
1	Vin +	Power supply positive	Input	30v	10.8v	-	-	-	-	-	48W (12V @ 4Amps) maximum power draw
2	Vin -	Power supply negative (ground)	-	-	-	-	-	-	-	-	System / chassis ground
3	Direction	Reverse/direction signal input	Input	100v	0v	3.5V min.	1V max	-	-	-	Input current is less than 1.0mA

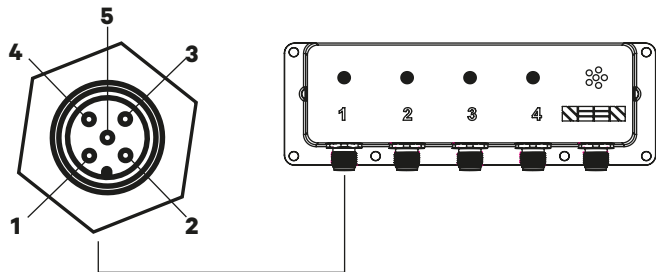

### Cab Box sensor cable socket (M12 5-pin x4)

Pin	Name	Description	Direction	Max. input voltage	Min. input voltage	Input high voltage	Input low voltage	Output high voltage	Output low voltage	Conditions	Notes
1	Vout +	Power supply output to IRIS 860 sensor or IRIS-i camera	Output	-	-	-	-	30V	0V	-	The output supply voltage matches the input supply voltage
2	Vout -	Power supply negative (ground)	-	-	-	-	-	-	-	-	System / chassis ground
3	System status	High when system is operating	Input	6V	0V	4V	1V	-	-	-	Green LED
4	Detection	High during detection	Input	6V	0V	4V	1V	-	-	-	Red LED
5	Reverse signal output	Reverse/direction signal output to IRIS 860 sensor or IRIS-i camera	Output	-	-	-	-	30V	0V	-	PNP output. The reverse output matches the supply voltage when the reverse/direction signal from the machine is high

Seen Safety Limited  
www.seensafety.com  
support@seensafety.com

IMPORTANT. SEEN IRIS 860 sensors can provide collision warning assistance to the operator but do not replace the need for proper operator training and best practice safe operating procedure. While IRIS 860 sensors can alert the machine operator to a potential collision, the operator is always fully responsible for the safe operation of the equipment. IRIS 860 sensors do not comply with the regulatory standards required for devices which are intended to directly control vehicle or machine safety functions. Using the sensor accessory port to control a vehicle or machine function is entirely at your own risk. Detection can never be guaranteed.

Copyright © 2022 Seen Safety Limited. All rights reserved. International patents pending and granted. Seen, Seen Safety, IRIS, IRIS-i are trademarks of Seen Safety Limited.

